

We can build you a complete 1948-56 Ford Pickup frame using your existing frame or exchange it. Options are similar to our 1935-40 Ford car frame exchange program.



1948-56 FORD TRUCK FRAME EXCHANGE PROGRAM

COMPLETE CHASSIS with IFS
Starting at **\$5,250.00** exchange

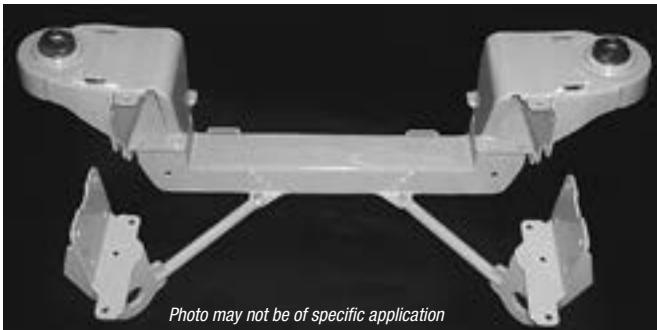

Photo may not be of specific application

1948-52 CHASSIS ENGINEERING BOLT-ON PINTO / MUSTANG II I.F.S. WITH ADJUSTABLE RIDE HEIGHT

This fully bolt-on crossmember uses Pinto or Mustang Suspension components. The stock Mustang/Pinto is too narrow to fit the 1948-52 Ford truck correctly, so Chassis Engineering has widened the crossmember and steering rack 2" and adjusted the pivot points. The result is suspension that is far superior to the original Mustang with no bump steer or other unpleasant surprises. The upper coil spring mounts are adjustable, giving 2-1/2" ride height adjustment at the wheel. This is the best method available to adjust ride height and maintain correct geometry. Center support rods add necessary strength to lower strut rod mounts and interlocking tabs between upper pods and crossmember prevent movement.

IF-4852FPT 1948-52 Ford pickup \$655.00
Complete suspension component package \$1,680.00



WELD-ON ENGINE MOUNTS INSTALLED OPTION

Engine mounts may be pre-welded to the above crossmember. Add \$80.00 to the kit price above.

CP-2151P Chevy small and big block V8 engine mounts . . \$95.00
CP-2251P Ford small block V8 engine mounts \$95.00

HANDY TOOL TO ADJUST RIDE HEIGHT ON THE C.E. I.F.S.

IF-0000W Adjustment wrench \$19.50

Trade in your original frame for a ready-to-roll street rod chassis! The basic package includes:

- An original 1948-56 Ford truck frame sandblasted, repaired and primed
- Overdrive trans X-member modification
- Heidis Mustang crossmember kit and tubular A-arms
- Mustang II front suspension. Includes: new 5-bolt rotors, shocks, springs, spindles, and a manual rack & pinion steering gear
- Small block Chevy or small block Ford front & rear motor mounts
- 8" Ford rear end-used (9" rear available)
- Chassis Engineering parallel leaf spring rear suspension
- Front and rear sway bars

1935-40/1941-48 exchange \$5,250.00

Chassis are also available outright without a frame trade-in Core Charge \$500.00

Above chassis with NEW 9" Ford rear, drum brakes and choice of gear ratios \$ 6,350.00

Please see page 12 for options



Photo may not be of specific application

1948-56 WELD-ON MUSTANG/PINTO IFS KIT

Uses 1974-1980 Pinto or 1974-1978 Mustang II suspension components. Same geometry as original Mustang. Includes all pieces needed for installation. Ready to weld-on and bolt up Pinto/Mustang suspension parts. Because this kit is the stock Pinto width, it fits the narrower 1941 better. Economy kit's welds are not dressed

PX-104 1948-52 Ford F-1 crossmember kit \$480.00
PX-105 1953-56 Ford F-100 crossmember kit . . . \$480.00

Call 402.886.2275 or click: www.heinzmanstreetrods.com

1948-1956 Ford Pickup Trucks

THE BEST RIDE IN TOWN FOR CLASSIC TRUCKS



HEIDTS SUPERIDE II FOR 1948-56 FORD TRUCKS

Give your Classic Ford truck a smooth ride, good handling, and the ultimate look with Heidts Superide II - *A complete front suspension kit which includes:* main crossmember, dropped spindles, adjustable tubular A-arms, adjustable coil over shocks with chrome springs, 11" disc brake vented rotors, billet calipers or GM calipers, front mounted rack and pinion steering, and factory ball joints & tie rod ends.

- BX-310** 1948-52 Ford pick-up\$3,295.00
- BX-316** 1953-56 Ford pick-up\$3,295.00

OPTIONS:

- Stainless steel control arms add \$1100.00
- Power steering add \$150.00
- Sway bar, plain \$200.00
- Sway bar, chrome \$415.00



1948-52 ENGINE MOUNTING KIT

Chassis Engineering kits include frame adapters, engine side mounts, thru bolt cushion set and instructions.

- CP-2150** Chevrolet small and big block V8 using original suspension. \$120.00
- CP-2250** Ford small block V8 using orig. susp. ... \$120.00



1948-52 TRANSMISSION CROSSMEMBERS

For trucks using a firewall swing type brake pedal assembly. Bolts to frame. Mounts most Ford and Chevrolet transmissions (Turbo 400 must use manual brakes with stock or C.E. pedal). Frame rails are straight in this area so transmission crossmember can be positioned as needed. Bolts and instructions included.

- ES-2150** 1948-52 Transmission crossmember. \$90.00

WITH MASTER CYLINDER MOUNT

For use with T-350, T-400, T-700, C4 Ford and Chevrolet transmissions. Includes a bracket to mount manual master cylinder under floor. Frame rails are straight in this area so transmission crossmember can be positioned as needed. Bolts to frame. Bolts and instructions included.

- ES-2051** above with M/C mount \$120.00



1948-52 FRONT AND REAR SWAY BARS

This is an excellent way to improve the handling and overall driveability of the Ford pickup. Eliminates road sway. For best results use front and rear bars together. Includes all linkage and mounting hardware.

- SB-0020PM** Front 1948-52 Fits C.E. IFS kit \$155.00
- SB-4852R** Rear 1948-52 Fits C.E. rear end kit. \$160.00

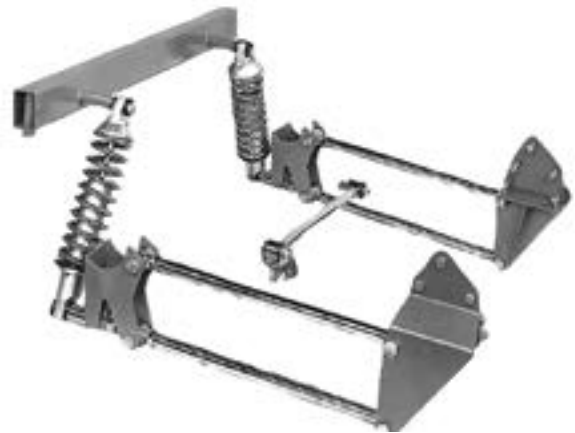

1948-52, 1953-56 FORD TRUCK 4-BAR KITS

Coil-over, 4-bar rear suspension provides the best ride for any classic truck. These kits attach directly to the stock frame rails. The adjustable axle brackets let you set ride height in one of three positions. A bolt-in upper crossmember for coil-overs is included. Kits available in plain steel or with polished stainless steel. Note: These kits require the use of a Panhard Rod. *Coil covers and panhard rod are sold separately*

- RB-1** 1948-52 Ford 4-bar kit, plain \$650.00
- RB-1SS** 1948-52 Ford 4-bar kit, stainless steel ..\$1,395.00
- RB-120** 1953-54 Ford 4-bar kit, plain \$650.00
- RB-120SS** 1953-54 Ford 4-bar kit, stainless steel ..\$1,395.00
- RB-121** 1955-56 Ford 4-bar kit, plain \$650.00
- RB-121SS** 1955-56 Ford 4-bar kit, stainless steel ..\$1,395.00

COIL OVERS

Aldan rear coil-overs are 15" extended, 11-7/8" compressed with spring rates of 180#, 200#, 220# and 250#. Other coil-overs sizes and spring rates are available.

- QA-1 Ultra-Ride** \$449.00

PANHARD RODS

Must be used with rear 1953-56 4-bar kits above

- RP-103** Bolt-on panhard rod kit, plain. \$105.00
- RP-103-SS** Bolt-on panhard rod kit, stainless steel .. \$305.00
- RB-110** Weld-on panhard rod kit, plain \$105.00
- RP-104-SS** Weld-on panhard rod kit, stainless steel . \$295.00

1948-1956 Ford Pickup Trucks



1948-52 COMPLETE REAR END MOUNTING KIT

Complete bolt-on kit that uses a wide variety of rear end choices. Uses two C.E. slider springs. Kit includes front and rear hanger brackets, 4 U-bolts and nuts, spring pads, rear shock kit with spring retainers, shocks, shackles, hardware and instructions.

AS-2020C 1948-52 Rear end kit. \$595.00

1948-52 REAR SPRING MOUNTING BRACKETS

This kit contains front and rear hanger brackets only from the above kit Includes bolts and instructions.

AS-2020 1948-52 Rear spring brackets only \$125.00

1948-52 REAR SHOCK KIT

Kit includes upper shock crossmember, two shock absorbers, two lower shock mounts from above kit and all needed bolts and instructions. Parts shown in the above kit photo

AR-2050 1948-52 Rear shock crossmember kit. . . \$145.00



1948-52 REAR SUSPENSION PARTS

REAR SHACKLES

AU-2214 For C.E. kitspair \$35.00

REAR SPRINGS

5 leaf, 2-1/2" wide, 5" free arch for use with AS-2020 brackets above.

RS-4148pair \$275.00

REAR AXLE U-BOLTS

AU-2025C Set of 4 with nuts \$35.00

REAR AXLE SPRING PADS

AU-2229 Weld-on \$25.00



1937-64 FORD TRUCK ECI BIG DISC BRAKE KIT

ECI's Disc Brake kits bolt-on to stock or reproduction 37-47, 48-56 and 57-64 1/2 ton pickup spindles. Kits include: GM full size car calipers/pads, 11 inch rotors with Ford or GM bolt pattern, bearings/adapters, seals, hardware, brackets and instructions

EC-701CK 1937-48 Ford P.U., GM 4-3/4" B.C. \$425.00

EC-705CK 1949-56 Ford P.U., GM 4-3/4" B.C. \$450.00

EC-709CK 1937-48 Ford P.U., Ford 4-1/2" B.C. \$450.00

EC-710CK 1949-56 Ford P.U., Ford 4-1/2" B.C. \$450.00

EC-730CK 1949-56 Ford P.U., Ford 5-1/2" B.C.* . . . \$450.00

EC-731CK 1957-64 Ford P.U., Ford 5-1/2" B.C.* . . . \$450.00

* uses Ford F150 rotors



Bracket shown may vary depending on applications

1948-56 POWER BRAKE UNITS

These assemblies include an ECI seven inch power brake booster and dual master cylinder. Bracket mounts unit to the frame and stock pedal assembly.

EC-524 1948-52 Ford 1/2 ton pickup \$425.00

EC-522 1953-56 Ford 1/2 ton pickup \$425.00

1953-56 Ford standard shift.add \$50.00



1948-52 BRAKE PEDAL AND PEDAL MOUNT KIT

Works with the under floor original brake pedal with slight pedal modification. Bolts and instructions included.

AS-2053 Pedal arm and mount assembly. \$168.00

AS-2054 Brake pedal mount only \$125.00

Call 402.886.2275 or click: www.heinzmanstreetrods.com

1948-1956 Ford Pickup Trucks