

# '28-'34 FORD

## HEINZMAN STREET RODS

1305 North "C" Road  
Phillips, Nebraska 68865  
Phone (402) 886-2275

### "DUCE FACTORY" FRONT 4-BAR KITS

#### Standard Cross Steering

MODEL A .....	3282C .....	\$355.00
'32-'34 .....	3282A .....	\$355.00
EXTRA LONG .....	3282X .....	\$355.00

#### Polished Stainless Cross Steering

MODEL A .....	3282CP .....	\$525.00
'32-'34 .....	3282AP .....	\$525.00
EXTRA LONG .....	3282XP .....	\$550.00

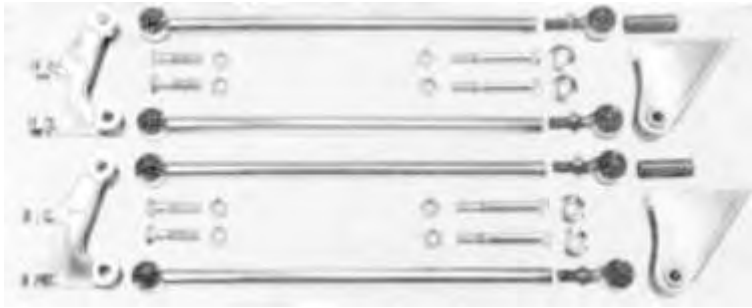

### STAINLESS STEEL BAT WINGS FOR FOR 4 BAR SUSPENSIONS

#### Standard Bat Wing

UNPOLISHED .....	3299 .....	\$125.00 pr.
POLISHED .....	3299P .....	\$155.00 pr.

#### New G T Bat Wing

UNPOLISHED .....	3299GT .....	\$125.00 pr.
POLISHED .....	3299GTP .....	\$155.00 pr.

### SHACKLES

#### STANDARD

FRONT (specify 1 <sup>3</sup> / <sub>4</sub> " or 2") .....	3221F .....	\$40.00
REAR (2 <sup>1</sup> / <sub>4</sub> ") .....	3221R .....	\$40.00

#### STAINLESS FRONT

POLISHED 1 <sup>3</sup> / <sub>4</sub> " .....	3355 .....	\$70.00
--	------------	---------



### CUSTOM STAINLESS 4-BAR BOLTS

3284 .....	\$95.00
------------	---------

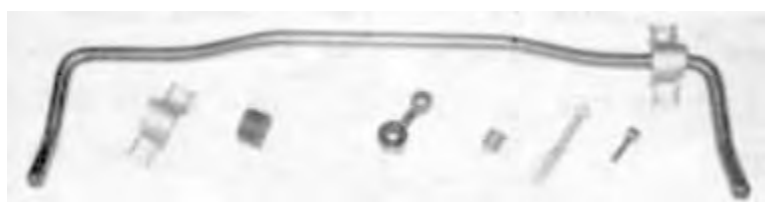

### FRONT SWAY BAR—SOLID AXLE

Completely bolt on unit fastens to the 4-bar bat wings. A big improvement in cornering and all around handling. Cures many steering problems. Includes bar, frame mounts, linkage, bolts and instructions. State axle used and size of bat wing to 4-bar bolt.

(<sup>1</sup>/<sub>2</sub> or <sup>9</sup>/<sub>16</sub>)

SB-2834F .....	\$139.50
----------------	----------

# HEINZMAN STREET RODS

1305 North "C" Road  
Phillips, Nebraska 68865  
Phone (402) 886-2275

# '28-'34 FORD



## FRONT SHOCK KITS

Our tube front shock kits are designed to be functional for the weight of the average Street Rod and to compliment the front end of your car. the kit includes shock absorbers, lower shock mounts, upper frame brackets and all necessary bolts, nuts & washers.

Model A and '32 weld-on .....	3222W .....	\$180.00
Model A and '32 bolt-on .....	3222B .....	\$190.00
'34 bolt-on .....	3223B .....	\$190.00

Above available with Chrome Shocks and Polished Stainless Lower Shock Mounts ..... \$255.00

## SPRING PERCHES AND LOWER SHOCK MOUNTS

Deuce Factory Stainless Perches .....	3219P .....	\$120.00
Stainless Lower Shock Mount .....	3218P .....	\$120.00
Unpolished S.S. Perches or Lower Shock Mounts .....		\$110.00



## FRONT TUBE SHOCKS

Plain .....	3300 .....	\$60.00 pair
Chrome .....	3300A .....	\$95.00 pair

## GM VEGA 140

Brand New

VEGA STEERING GEAR .....	\$329.00
--------------------------	----------

PITMAN ARM .....	\$70.00
------------------	---------



## SHOCK FRAME BRACKETS

Top quality die stamped brackets

Model A and '32 Weld-on .....	3324 .....	\$39.00
Model A and '32 Bolt-on .....	3325 .....	\$45.00
'34 Bolt-on .....	3325A .....	\$45.00



# '28-'34 FORD

## HEINZMAN STREET RODS

1305 North "C" Road  
Phillips, Nebraska 68865  
Phone (402) 886-2275

### VINTAGE CHASSIS FORGED I-BEAM & TUBE AXLES

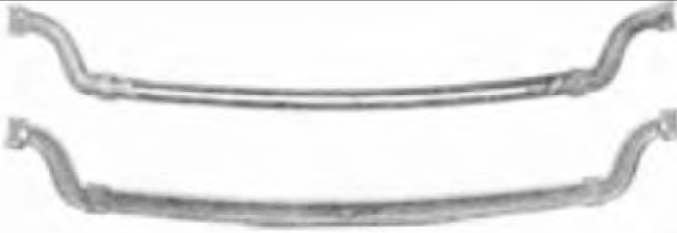

Fits Ford Spindle 1937-48 4" drop. State 2" or 2 1/4" perch boss. 47" width. 1928-48 Ford. Forged axles are several times stronger than cast type. Narrower width is ideal for Ford.

Requires special main leaf. 1 1/2" narrower between perches.  
**AU-2107 ..... \$275.00**

### CHASSIS ENGINEERING FORGED SPINDLES

Precision replacement for 37 to 41 Ford spindle ..... **\$239.00**  
Complete with King Pins Fitted ..... **\$295.00**  
Also Available machined for GM Rotors



### KING PIN SETS

37 to 41 Ford ..... **3269 ..... \$60.95**  
42 to 48 Ford ..... **3279 ..... \$60.95**

### FORGED SPINDLE ARMS

Double end on right. Ford spindles.  
For use with dropped axles.

Standard ..... **AU-2119 .... \$119.00 pr.**  
Milled for GM Brake kit ..... **\$127.50 pr.**



### FORD TIE ROD ENDS (with jam nuts)

Right Hand 3237R ..... **\$24.00**  
Left Hand 3237L ..... **\$24.00**  
Stainless Steel Tie Rod Ends ..... **\$45.00**

### TIE ROD & DRAG LINK

Made from 7/8" seamless tube with for tie rod end and jam nuts. Made to fit Super Bell Axle or specify center to center length.

Tie rod & drag link ..... **2180 ..... \$85.00**  
Polished S/S Tie Rod Assembly ..... **\$212.00**



### VEGA STEERING ADAPTER

Recommended steering for '28 to '34.  
Must be welded to boxed frame.

**AR-2130 ..... \$45.00**

# HEINZMAN STREET RODS

1305 North "C" Road  
Phillips, Nebraska 68865  
Phone (402) 886-2275

# '28-'34 FORD



## EASY RIDER FRONT SPRING

C.E. springs feature leaf ends that are rolled thin and diamond cut for traditional Street Rod styling. Special sliders are installed at the end of each leaf and are locked in place so they can't work out. The sliders do not show; locking tabs are hidden by next leaf up. Nothing shows to mar the smooth lines. The result of these features compliment each other for the best appearing and working early Ford spring available.

**FS 2834** ..... \$105.00  
**Reversed eye main leaf** ..... **FS2834M** ..... \$40.00



## FRONT U-BOLTS & SPRING PAD

**U-Bolts with Lock Nuts**  
**Spring Pads** ..... \$42.95 a set  
**StainlDss Steel U-bolt and pad set** ..... \$89.00 a set



## STEERING U-JOINTS

Forged steel with roller bearings make this the best joint available. Specify Vega, Chevy manual, Chevy power, Mustang early, Pinto manual, Pinto power.

**U-JOINTS** ..... \$68.00  
**SPINE SHAFTS (specify length)** ..... \$42.00



## POLYPROPYLENE

Polypropylene between spring leaves reduces friction and wear, allowing the spring to move freely for a better ride.

**AU-2066 1<sup>3</sup>/<sub>4</sub>"** ..... \$12.00  
**AU-2067 2"** ..... \$14.00  
**AU-2068 2<sup>1</sup>/<sub>4</sub>"** ..... \$16.00



# '28-'34 FORD

## HEINZMAN STREET RODS

1305 North "C" Road  
Phillips, Nebraska 68865  
Phone (402) 886-2275



### ALDAN COIL OVER SHOCK ASSEMBLIES

Coil Over Shocks are available with plain or polished aluminum shock bodies. Spring height adjustment is by a threaded spring seat and locking ring. Shock rate is adjustable using 6 position adjustment knob.

Front Shocks #657 ..... 13<sup>1</sup>/<sub>2</sub>" Extended  
..... 10<sup>1</sup>/<sub>4</sub>" Compressed  
Spring Rates 300-350-400-450-500-550#  
Rear Shocks #654 ..... 15" Extended  
..... 11<sup>7</sup>/<sub>8</sub>" Compressed  
Rear Shocks #658 ..... 16 <sup>1</sup>/<sub>2</sub> Extended  
..... 12 Compressed  
Spring Rates 180-200-220-250-300-350-400-450-500-550#

Front Coil Over 656 ..... \$410.00  
Rear Coil Over 654 ..... \$410.00  
Rear Coil Over 658 ..... \$415.00  
Coil Overs - Ultra-Ride ..... \$449.00  
1/2 Berrina Ends ..... add \$20.00  
(Chrome Springs Available)



### STAINLESS ADJUSTERS

Straight <sup>5</sup>/<sub>8</sub>-18 adjuster ..... 293 ..... \$25.00  
Straight <sup>3</sup>/<sub>4</sub>-16 adjuster ..... 3293B ..... \$25.00  
11 angled <sup>5</sup>/<sub>8</sub>-18 adjuster ..... 3294 ..... \$25.00  
7 angled <sup>5</sup>/<sub>8</sub>-18 adjuster ..... 3295 ..... \$25.00  
(All part numbers include Jam Nuts)  
Add \$4.00 for polished



### URETHANE "90" BUSHINGS

Front 4-Bar Urethane 90 Bushings ..... 3259 B ..... \$5.50  
Rear 4-Bar Urethane 90 Bushings ..... 3312B ..... \$5.50  
Stainless Washers  
Front 4-Bar polished <sup>1</sup>/<sub>2</sub> <sup>4</sup>/<sub>16</sub> & <sup>5</sup>/<sub>8</sub> ..... 3278A ..... \$3.50



### STEEL SLEEVES

#### FOR URETHANE "90" BUSHINGS

Front 4-Bar sleeves ..... 3259A ..... \$4.50  
Rear 4-Bar sleeves ..... 3312A ..... \$4.50



### HEIDT'S "SUPER RIDE" INDEPENDENT FRONT SUSPENSION KIT

For Model A, '32 Ford, & '33-'34 Ford

Independent front suspension gives you twice the ride of a new 4 link dropped axle at a comparable cost. Kit includes main crossmember, dropped spindle, adjustable 4-arms, Wilwood calipers, 11" rotors, adjustable coil overs, new rack & pinion, stainless adjusters with urethane bushings, & factory ball joints and tie rod ends ..... \$2695.00  
(Add \$495.00 for stainless A-Arms)

# HEINZMAN STREET RODS

1305 North "C" Road  
Phillips, Nebraska 68865  
Phone (402) 886-2275

# '28-'34 FORD

## REAR TRIANGULATED 4-BAR KIT

The Deuce Factory's rear triangulated 4-bar kit is an ideal way to mount your rear end. The design is very similar to that used by General Motors. All brackets are die stamped in  $\frac{3}{16}$ " steel. The tubing used is 1" by .156" wall and equipped with urethane bushing available in steel or polished stainless steel.

### Standard:

Model A .....	3364 .....	\$375.00
'32-'34 .....	3296 .....	\$375.00

### Polished Stainless:

Model A .....	3364P .....	\$550.00
'32-'34 .....	3296 .....	\$550.00

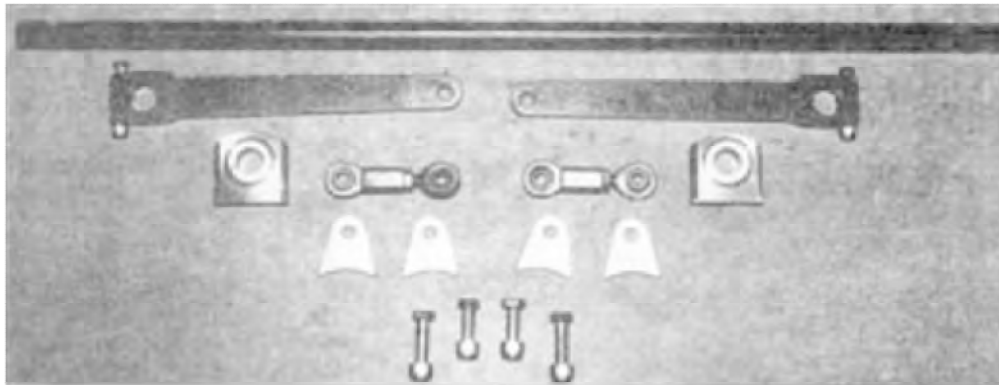

## REAR STABILIZER BAR KIT

Most street rods today are utilizing the coil spring suspension which gives a softer ride but will tend to have more roll in the chassis. To increase the roll stiffness in the chassis, this roll bar will greatly help. The bar is  $\frac{3}{4}$ " round, 27" long with 48 splines on the ends of the bar to correspond with the arms. The hole to hole arm length is 8". The bar is mounted to the rear cross member with aluminum pillow blocks and the arms mount to the rear housing with rod end links.

'32-'34 .....	3298 .....	\$245.00
Model A .....	8098 .....	\$199.00

## PARALLEL 4-BAR KITS

The Parallel 4-Bar Kit is very easy to install and is a good choice for many installations. It uses 1" x .156 tube bars with  $\frac{3}{4}$ " stainless adjusters and urethane bushing, chassis mounting brackets, multi-position coil-over axle brackets and hardware.

NOTE: These kits require the use of a Panhard Rod.

Model A; Rear: Plain .....	2017 .....	\$375.00
'32 Ford; Rear: Stainless .....	3017 .....	\$375.00
'34 to '40 Ford: Plain .....	4017 .....	\$375.00
Universal; Rear .....	4017RP .....	\$375.00
Chrome .....	add .....	\$110.00



# '28-'34 FORD

## HEINZMAN STREET RODS

1305 North "C" Road  
Phillips, Nebraska 68865  
Phone (402) 886-2275

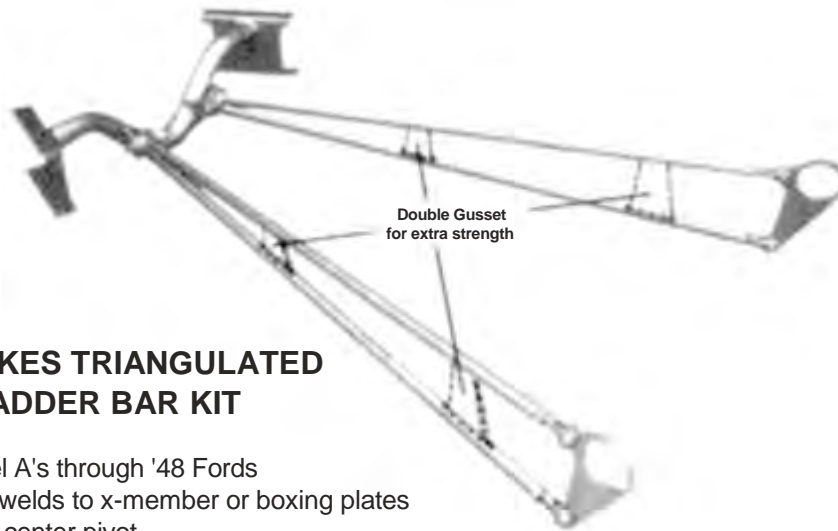

### PETE AND JAKES TRIANGULATED REAR LADDER BAR KIT

- Mounts rear end into Model A's through '48 Fords
- Pre-welded crossmember welds to x-member or boxing plates
- Urethane bushings at front center pivot
- Adjustable clevis at rear
- Ultimate in strength and traction  
(specify rear axle housing diameter)

'28-'31 Model A .....	2011 .....	\$395.00
'32 Ford .....	3011 .....	\$395.00
'33-'44 Ford .....	4011 .....	\$395.00
'35-'48 Ford .....	5011 .....	\$395.00

### DRAG STRIP VERSION TRIANGULATED LADDER BAR KIT

Double gusset for extra strength

'28-'31 Model A .....	2011 DR .....	\$439.00
'32 Ford .....	3011 DR .....	\$439.00
'33-'34 Ford .....	4011 DR .....	\$439.00
'35-'48 Ford .....	5011 DR .....	\$439.00

### REAR COIL OVER SHOCK SUSPENSION KIT

- Tube crossmember, boxing plates, upper shock mounts
- Panhard bar with axle and frame brackets
- Lower shock Mounts with 3 vertical positions to adjust ride height
- Works with viper coil overs or others

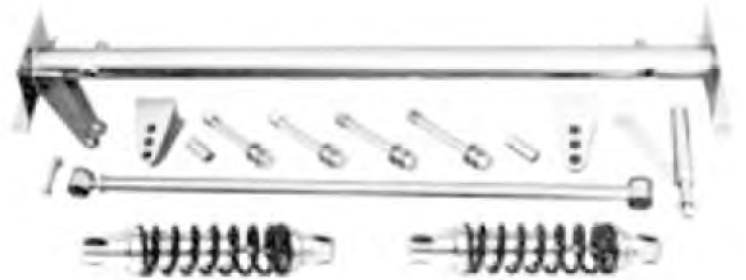

'28-'31 Ford .....	2013 .....	\$141.50
'32 Ford .....	3013 .....	\$309.00
'33-'34 Ford .....	4013 .....	\$309.00
'35-'48 Ford .....	5013 .....	\$309.00

### COIL OVERS

- Designed exclusively for hot rods and pro street machines
- Made of 6061T-6 Aluminum Alloy
- Gas Charged for superior, fade free damping
- A five position damping adjuster lets you select ride
- Special vented oil cavity protects top seal from excessive pressure - solves the problem of leaking shocks (spring rates: 12 to 550#)

#### ALDAN COIL OVERS

Rear, 13.4 open x 10.2 closed .....	654 .....	\$410.00
Front, 13 open x 10 closed .....	657 .....	\$410.00
Rear, 16 1/2 open x 12 closed .....	658 .....	\$415.00

#### QA1 COIL OVERS

Ultra-Ride, 14 open x 10 closed .....	4855 .....	\$449.00
Ultra-Ride, 17 open x 12 closed .....	5855 .....	\$449.00

