



SPEED CONTROL ARM AND SPINDLE KIT

The Detroit Speed control arm and spindle kit is designed to work as an integrated system to improve handling. Detroit Speed's spindle is 1-1/2" taller than the stock spindle with 2" of drop. The taller spindle height modifies the camber curve resulting in a negative camber gain during suspension compression. The stock steer arms mount in the optimal location to minimize bump steer.

The tubular control arms provide increased strength and rigidity. They come with Delrin bushings, new ball joints and have a gloss black powder coat finish. Upper control arms are designed with additional positive caster and include the cross shaft. The lower control arms feature a robust tubular design with gussets and a cross brace.

- 030104 1964-66, A-Body \$1790.00
- 030105 1967-72, A-Body \$1790.00

DSE CHEVELLE/GM A-BODY SPEED KITS

Detroit Speed's front suspension kits combine individual components into a system designed for your vehicle at three different levels. The DSE Speed Kit 1 provides the ease of bolt-on components to improve your A-Body's handling. The Speed Kit 2 improves the handling performance to the next level and offers ride height adjustment. The Speed Kit 3 is the most advanced handling system you can buy for use with the stock frame. It gives you the ultimate steering performance of today's modern performance cars.

Speed Kit 1: tubular upper control arms, tubular lower control arms with stock spring pocket, Koni classic front shocks, DSE increased spring rate springs, DSE forged 2" dropped spindle.

Speed Kit 2: Kit #1 with DSE coil-over conversion kit, DSE tubular sway bar.

Speed Kit 3: kit # 2 plus splined front sway bar, DSE 600 steering gear with rag joint and pitman arm, DSE tie rod adjusters, inner and outer tie rod ends and idler arm. Ceramic finish Steering Box \$80 extra.

- 031309 1964-66, Speed Kit 1 (specify SB, BB, LS) . . \$2460.00
- 031310 1967, Speed Kit 1 (specify SB, BB, LS) . . . \$2460.00
- 031311 1968-72, Speed Kit 1 (specify SB, BB, LS) . . \$2460.00
- 031317 1964-66, Speed Kit 2 (specify SB, BB, LS) . . \$2715.00
- 031321 1967, Speed Kit 2 (specify SB, BB, LS) . . . \$2715.00
- 031318 1968-72, Speed Kit 2 (specify SB, BB, LS) . . \$2715.00
- 031323 1964-66, Speed Kit 3 (specify SB, BB, LS) . . \$4172.00
- 031329 1967, Speed Kit 3 (specify SB, BB, LS) . . . \$3982.00
- 031324 1968-70, Speed Kit 3 (specify SB, BB, LS) . . \$3982.00
- 031325 1971-72, Speed Kit 3 (specify SB, BB, LS) . . \$4208.00



A-BODY COIL SPRINGS

Give your A-Body a modern Pro-Touring stance while improving ride and handling with DSE A-Body coil spring kits. Available in either stock ride height or a 2" drop (from stock). Rear springs give a 1-1.5" drop.

- 031109 1964-66, Stock (specify SB, BB, LS) pr. . . . \$190.00
- 031111 1968-72, Stock (specify SB, BB, LS) pr. . . . \$190.00
- 031109 1964-66, 2" drop (specify SB, BB, LS) pr. . . . \$190.00
- 031111 1968-72, 2" drop (specify SB, BB, LS) pr. . . . \$190.00
- 041802 1964-66, Rear, 1.25-1.5" drop, pr. \$190.00
- 041804 1967-72, Rear, 1" drop, pr. \$190.00

A-BODY FRONT REPLACEMENT SHOCKS

These Koni Classic rebound adjustable shocks bolt-in the stock location. They use the latest in shock absorber technology to give your car a modern feel while maintaining comfortable ride characteristics.

- 031007 1964-72, Stock front shocks pr. \$250.00
- 041306 1964-72, Stock rear shocks pr. \$250.00

1964-1972 Chevy Chevelle Suspension

1964-1972 Chevelle suspension



DSE A-BODY SWAY BARS

DSE's tubular 1-3/8" front sway kit provides a dramatic improvement on cars with stock suspension and optimal improvement on cars fitted with other DSE components. Kit includes sway bar, greaseable polyurethane bushings, mounts and end links.

The splined sway bar kit is tuned to provide the ultimate in performance, ride, and handling. It uses a 1-1/2" OD hollow 4130 alloy heat-treated splined sway bar, black hardcoated 6061-T6 billet aluminum pillow blocks with Delrin bushings, 3/4" thick solid steel sway bar arms, low-friction ball style end-link system. Bolt-on 1968-72 A-Bodies; 1964-66 A-Body sway bar mounting holes need to be drilled and tapped up to 3/8".

- 031403 1964-67, Tubular sway bar \$225.00
- 031402 1968-72, Tubular sway bar \$225.00
- 031404 1964-72, Splined sway bar kit \$800.00

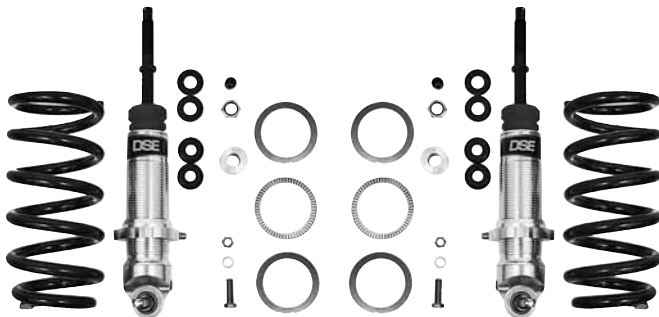

DSE FRONT COILOVER KIT

Now you can bolt the latest coil-over spring/shock technology to any GM A-Body. The specific DSE valving will bring your classic's handling and ride into the 21st century. The base coil-over package offers extensive ride height adjustment and special DSE valving. Optional double adjustable coil-overs offer both compression and rebound tuning. The monotube remote reservoir coil-over set is the ultimate package and offers separate fluid canisters for optimum adjustability, 1" more stroke and improved heat dissipation.

- 030306 1964-72, A-Body (specify SB, BB, LS) \$1000.00
Call for pricing on shock options



HEIDTS GM A-BODY CONTROL ARMS

HEIDTS tubular upper and lower control arms for the '64-'72 Chevelle and all other GM A-body cars are state of the art in both design and fabrication. Uppers are 1-1/4" dia. tube, and the lowers are a full 1-1/2" tube. They are powder coated and completely assembled with ball joints and urethane bushings. High performance urethane bushings tighten up the suspension and allow no deflection under cornering loads for absolutely solid, positive handling. Upper arms include offset cross shafts for easier alignment and adjustment of caster settings.

- CA-401 1964-72 A-Body upper control arms \$379.00
- CA-411 1964-72 A-Body lower control arms \$559.00
- CA-411-M 1964-72 Coil-over lower control arms . . . \$559.00

Heidt's Pro-G dropped spindles (SP-110) are recommend with our control arms.

HEIDT'S TALL 2" DROPPED STEEL SPINDLE

The upper ball joint is raised 1-1/2" over the factory design to yield a better camber change during suspension movement. This corrects the excessive camber change of the original design. These spindles are STEEL, the strongest ones in the industry.



- SP-110 2" Dropped Spindles Pair \$299.00

HEIDT'S COIL OVERS

These shocks are fully adjustable with just the turn of a knob in both compression and rebound for full performance tuning. Ride height is also tunable with adjustment rings. Powder coated springs in different spring rates are included.



- CS-040 Coil-over shocks, pr. \$339.00
- CQ-450-11 450# 11" Coil-over springs, small block . . \$150.00
- CQ-550-1i 550# 11" Coil-over springs, big block . . . \$150.00
- CQ-010 Thrust bearings for coil-over shocks \$35.00
- TA-001 Spanner wrench \$15.00



HEIDT'S A-BODY SWAY BARS

Completely bolt-on with the supplied hardware.

- SB-071 1964-72 1 1/8" Chevelle Front Swaybar . . \$179.00
- SB-150 1964-72 1" Chevelle Rear Swaybar** . . . \$169.00

**Must use HEIDTS rear 4-Link package



GM-DELPHI 600 POWER STEERING GEAR

This all new steering gear replaces the common GM 800 series power steering gear used from 1964 to 1992. It uses low friction gear design and precision rack and pinion valve technology for increased steering feel. Quick ratio 12.7:1 and 6 lbs lighter than stock. Original power pitman arm may be used. A 3/4 x 30 spline rag joint and new o-ring power steering hoses are needed

- 090204 1964-72 A-Body, ready to paint \$495.00
- 090204C 1964-72 A-Body, Ceramic coated. \$575.00
- 090205 Rag Joint, connects to stock column \$90.00
- 091202 Steering hose kits for 600 gear box \$150.00



HEIDT'S CHEVELLE REAR 4-LINKS

Tighten up the handling of your A-Body by eliminating the stock suspension flex. These upper links are adjustable, 1-1/4" dia. tube, and the lowers area full 1-1/2" x 2" square tube. They're powder coated black and are supplied with greaseable swivel and fixed high performance urethane bushings installed. Urethane bushings tighten up the suspension and the swivel ends allow roll deflection under cornering loads for absolutely solid, positive handling. Completely assembled and includes all new hardware.

- RC-240 1964-66 GM A-Body rear 4-link. \$618.00
- RC-250 1967-72 GM A-Body rear 4-link. \$618.00



UNISTEER POWER RACK & PINION CONVERSION

Sharpen up the lack luster steering in your classic Chevelle and A Bodies. This rack & pinion kit greatly improves the handling and steering response, without having to chop or modify your stock frame. This kit improves the stock geometry, eliminating the bump steer found in the stock suspension. Kit is complete with pump assembly and steering shaft.

- 8010780-01 1964-67 A-Body power rack & pinion kit. . \$1747.00
- 8010740-01 1968-72 A-Body power rack & pinion kit. . \$1747.00



HEIDT'S REAR CHASSIS BRACE LINKS

These links tie the upper frame mount of the rear 4-links to the chassis crossmember to eliminate flex. They take the added stress from the new rear 4-links. Sold in pairs.

- RC-255 1964-66 GM A-Body \$140.00
- RC-251 1967-72 GM A-Body \$140.00

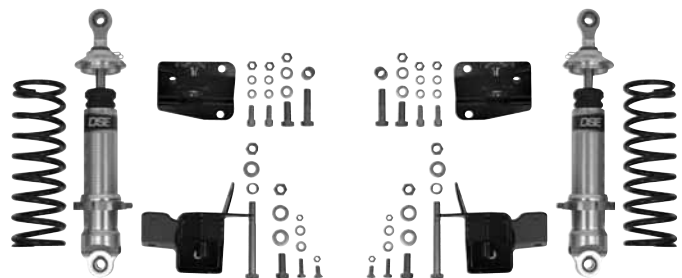

DSE REAR COILOVER KIT

Bolt the latest coil-over spring/shock technology to any GM A-Body. The base coil-over package offers extensive ride height adjustment and special DSE valving that will bring your classic's handling and ride into the 21st century. Optional double adjustable coil-overs offer both compression and rebound tuning. For the ultimate, use the monotube remote reservoir coil-over set with separate fluid canisters for optimum adjustability, 1" more stroke and improved heat dissipation. Kit includes, springs, shocks and brackets.

- 042410 1964-66, A-Body. \$1,000.00
- 042411 1967, A-Body. \$1,000.00
- 042411 1968-72, A-Body. \$1,000.00

Call for pricing on shock options



DSE ALUMINUM POWER STEERING PUMP

This pump is compatible with any power steering box or rack. These are new, not remanufactured pumps. Integral black plastic reservoir is included. Available polished, in cast iron, or without the reservoir for remote fill.

- 090901 Aluminum power steering pump w/res . . . \$195.00
- 090301 Aluminum power steering pump w/o res . . \$175.00
- 091001 Cast iron power steering pump w/res \$155.00
- 090801 6" V-belt PS pulley \$68.00

Call 402.886.2275 or click: www.heinzmanstreetrods.com

1964-1972 Chevelle Suspension

1964-1972 Chevelle suspension



DSE REAR SPEED KITS

Our Speed kits are designed to provide optimum geometry and tire contact through the full range of rear suspension travel. With Swivel Links™, the rear end housing becomes fully articulated, without the use of noisy spherical heim joints. The tubular rear sway bar attaches to the chassis for a substantial improvement in cornering ability. The rear Speed Kit springs, shock absorbers and sway bars are designed to complement the front DSE Speed Kits, giving your A-Body handling and ride quality on par with the latest modern muscle cars.

Speed Kit 1: includes: patented Swivel-Link™ rear control arms and DSE chassis brace kit

Speed Kit 2: includes Kit 1, plus: DSE rear coil springs, Koni classic shock absorbers, DSE tubular rear sway bar

Speed Kit 3: includes all of the above and replaces the stock style springs and shocks with DSE specific rear coil-over shocks & springs

041603	1964-67, Speed Kit 1\$960.00
041604	1968-72, Speed Kit 1\$960.00
041607	1964-66, Speed Kit 2\$1790.00
041609	1967, Speed Kit 2\$1790.00
041608	1968-72, Speed Kit 2\$1790.00
041611	1964-66, Speed Kit 3\$2373.00
041613	1967, Speed Kit 3\$2373.00
041612	1968-72, Speed Kit 3\$2373.00



DSE TUBULAR REAR SWAY BAR

The DSE 1 1/8" tubular steel rear sway bar offers many advantages over the non-effective stock rear bar. DSE's bar attaches to the rear end housing and to the chassis crossmember, not the lower control arms like the OEM set-up. The DSE bar mounts to the chassis with Swivel-Links™ (Patented), eliminating binding through the range of rear suspension travel. The bar comes powder coated in a high gloss black finish and includes all necessary mounting hardware.

042201	1964-72 Rear sway bar kit\$385.00
--------	---------------------------	---------------

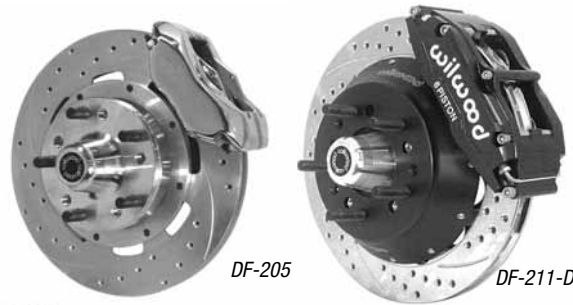

WILWOOD DISC BRAKE KITS

Four piston calipers, 11" rotors, 15" wheels, stock spindles .19" wheel offset

Use with either manual or power boost master cylinders. Kits come complete forged billet Dynalite calipers, rotors, hub assembly, brackets and hardware. Requires purchase of additional brake lines.

- 220-7056 Black anodize calipers, un-drilled rotors . \$764.16
- 220-7056 Black anodize, drilled & slotted \$879.97

There are many color and finish options available

Six piston calipers, 14" rotors, 18" wheels, stock spindles

The ultimate in big brakes for extreme performance and show. Manual or power boost master cylinders. Kits come complete with calipers, rotors, hub assembly, brackets and hardware.

- 140-10920 Black anodize calipers, slotted rotors . . \$2,303.56
- 220-7056 Black anodize, drilled & slotted rotors . \$2,415.97

Wilwood Discs Brakes For Heidt's Dropped Spindles

DF-205	11" drilled rotors, 4 piston polished calipers & hardware*	\$895.00
DF-205-D	11" drilled rotors w/ polished hubs, 4 piston polished calipers & hardware* .	\$1,050.00
DF-210-D	12" drilled rotors w/ polished hubs, 4 piston polished calipers & hardware* .	\$1,075.00
DF-211-D	13" drilled rotors w/ black hubs, 4 piston black calipers & hardware* . . .	\$1,995.00



HEIDT'S POWER BOOSTER & DUAL MASTER CYLINDER

Bolt-on kits for 67-81 Camaros. Kit includes: power booster, dual master cylinder and correct proportioning valve for disc-drum or disc-disc cars. Designed for use with our Disc Brake Kits. Fully assembled and plumbed, ready for installation.

- DB-114 64-66 A-Body booster w/mc for disc/drum . . \$299.00
- DB-114-D 64-66 A-Body booster w/mc For disc/disc . . \$299.00
- DB-115 67-72 A-Body manual master for disc/drum. \$175.00
- DB-115-D 67-72 A-Body manual master for Disc/Disc . \$175.00