

COMPLETE FINISHED FRAMES: We can build you a complete 1937-59 Chevy pickup frame using your existing frame or exchange it. Options are similar to our '35-40 Ford car frame exchange program. *Please see page 12.*



1937-1959 Chevy Pickup Suspension



ENGINE MOUNTING KIT

Includes bolt-on frame adapters (can also be welded on), Chassis Engineering engine side mounts, thru bolt cushion set, hardware and instructions. Easy to install.

- CP-1160 Engine Mounting Kit \$93.75**
- CP-1160G Engine Mounting Kit- weld-on for non-CE Pinto/Mustang IFS crossmembers. \$93.75**



BOLT-ON PINTO/MUSTANG II I.F.S. WITH ADJUSTABLE RIDE HEIGHT

Fully bolt-on Chassis Engineering crossmember uses Pinto/Mustang II factory geometry and suspension components. The standard Mustang track is increased 2" to fit the wider Chevy trucks correctly. The upper coil spring pads are adjustable, giving 2-1/2" of ride height adjustment at the wheels. Includes strut rod frame brackets with reinforcing rods that tie into the crossmember in for extra strength. Upper spring pads interlock with crossmember for rigidity.

- IF-4854CPT 1948-54 Chevy Truck-1/2 ton only. . . . \$625.00**
- CP-1160P with welded on engine mounts installed . \$625.00**

TRANSMISSION CROSSMEMBERS

Bolt on assembly uses original holes. Fits Turbo 350 and others measuring 20 5/8" from engine to mount center holes.

- ES-1164 1940-1947 -T-350, PG and manual \$75.00**
- ES-1165 1948-1954 -T-350, PG and manual \$68.00**
- ES-1166 1940-1947 -700R4. \$75.00**
- ES-1167 1948-1954 -700R4. \$68.00**

For transmissions not listed, use universal crossmember. Specify bolt on or weld on ends.

- AT-1056 Universal Crossmember \$65.00**



WELD ON PINTO/MUSTANG II IFS KIT

This Heidt's weld-on kit includes lower crossmember, upper spring mounts, boxing plates, rear strut mounts, gussets and instructions to mount '74-'78 Mustang II or '74-'80 Pinto/Bobcat front suspension to your '37 to '54 Chevy truck. Gives a low stance and nice ride. Economy kit does not have dressed welds. Note: requires extensive welding.

- CX305 1937-1939 Pickup. \$399.00**
- CX306 1940-1946 Pickup, standard \$399.00**
- CX307 1947-1954 Pickup. \$399.00**
- CX308 1955-59 Pickup. \$399.00**

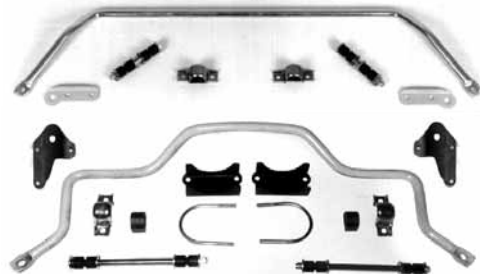

FRONT AND REAR SWAY BARS

Improves the handling of top-heavy classic trucks. For best results use front and rear bars together. Linkage and mounting hardware furnished. Upper linkage mount must be fabricated for rear bar.

- SB-0037R Rear- for Chassis Engineering rear end kit (specify axle housing diameter). \$134.50**
- SB-0010PM Front- most stock width Mustang IFS kits \$129.50**



HEIDT'S SUPER RIDE II FOR 1947-54 CHEVY TRUCKS

Give your Classic Chevy truck a smooth ride, good handling, and the ultimate look with Heidt's Superide II - A complete front suspension kit which includes: main crossmember, dropped spindles, adjustable tubular A-arms, adjustable coil over shocks with chrome springs, 11" disc brake vented rotors, billet calipers or GM calipers, front mounted rack and pinion steering, and factory ball joints & tie rod ends.

BX-306 1947-54 Ford pick-up \$2795.00

Options: Stainless steel control arms add \$579.00

Power steering add \$50.00

Polished billet calipers add \$200.00

Sway bar, plain \$163.00

Sway bar, Chrome \$239.00

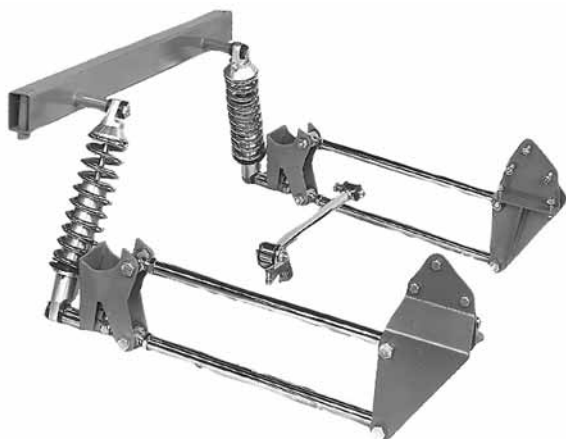

HEIDT'S 1947-59 CHEVY TRUCK 4-BAR KITS

Coil-over, 4-bar rear suspension provides the best ride for any classic truck. These kits attach directly to the stock frame rails. The adjustable axle brackets let you set ride height in one of three positions. A bolt-in upper crossmember for coil-overs is included. Kits available in plain steel or with polished stainless steel. Note: These kits require the use of a panhard rod. Coil covers and panhard rod are sold separately

RB-112 1947-54 Chevy 4-Bar Kit, Plain \$439.00

RB-112SS 1947-54 Chevy 4-Bar Kit, Stainless Steel \$985.00

RB-110 1955-59 Chevy 4-Bar Kit, Plain \$439.00

RB-110SS 1955-59 Chevy 4-Bar Kit, Stainless Steel \$985.00

HEIDT'S COIL OVERS

Rear coil overs are 15" extended, 11 7/8" compressed with spring rates of 180#, 200#, 220#, 250#, 300#, 350#, 400# and 500#. Shocks are available plain or polished and springs are chrome.

BX-029 Coil Overs, plain \$379.00

BX-038 Coil Overs, polished \$429.00

PANHARD RODS

Must be used with rear 1947-54 4-bar kits above

RP-105 Bolt-on panhard rod kit, plain \$95.00

RP-105-SS Bolt-on panhard rod kit, stainless \$195.00



AS-1015 shown

REAR END MOUNTING KITS

1948-54 Bolt-On Kit includes bolt-on spring mounts, (4) U-bolts with nuts, specially valved shocks, shackles, rear shock kit and Chassis Engineering Slider Springs. Spring pads must be welded to rear axle. This is an easy installation on original frames

AS-1015C 1948-54 Bolt On Rear End Kit. \$484.00

1937-47 Weld-On Kit includes weld-on spring mounts, (4) U-bolts with nuts, specially valved shocks, shackles, rear shock kit and Chassis Engineering Slider Springs. Spring pads must be welded to rear axle. Fitting and welding required. Specify rear end used.

AS-0010CY 1937-47 Weld-on rear end kit \$479.00

Add gas shocks to above kits add \$20.00

SPRING OPTIONS Please specify "Regular" for normal usage or "Heavy Duty" for heavier loads such as sedan delivery. Kit comes with specially valved shocks.

BRAKE PEDAL & MASTER CYLINDER MOUNTING KIT

Bolt-in mounts adapt most master cylinders

AS-1048PT 1947-54 Chevy PU. . \$161.15



ECI MASTER CYLINDER ADAPTER

Adapts either Mustang or Corvette master cylinder to the stock brake pedal in the stock master cylinder location. Supplied with push rod, rod end, hardware and new boot.

EC-420 1947-54 Chevy P/U \$89.95

EC-425 1955-59 Chevy P/U \$125.00



EC-515 shown



EC-420 shown

ECI BOOSTER & MASTER CYLINDER ASSEMBLY

New master cylinder with 7" booster and bracket. Mounts to the stock brake pedal. Hardware included

EC-505 47-54 Chevy pick-up \$395.00

EC-515 55-59 Chevy pick-up. \$395.00

ECI DISC BRAKE KITS

Uses GM rotors and calipers (large passenger car) and replaces the Chevy ball bearings with late GM/ tapered roller bearings and grease seals. Caliper brackets bolt to the stock spindles and stock GM steering arms are used.



EC-711 47-54 Chevy, basic kit. \$180.00

EC-711CK 47-54 Chevy, complete kit \$450.00

EC-711X 47-54 Chevy, basic kit. \$180.00

EC-711XCK 47-54 Chevy, complete kit \$450.00

Call 402.886.2275 or click: www.heinzmanstreetrods.com

1937-1959 Chevy Pickup Suspension