

1937-1939 Chevy Suspension

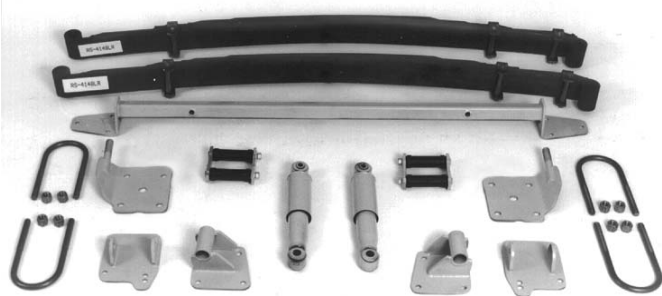

REAR END MOUNTING KIT

Bolt-on kit with no modifications of any kind to rear end. Easy installation, just remove old mounts and bolt these in their place. Kits include right and left front and rear spring mounts, 4 U-bolts and nuts, rear shock kit with spring retainers, shocks, shackles, slider springs, bolts, and instructions. Kits use 1968-1976 Nova multi-leaf rear ends or 1967-1969 Camaro or Firebird. Best choice is the Ford Granada and Monarch rear ends (8 inch). To use other rears, spring pads must be welded on rear end.

- AS-1016CC** 1937-39 for Camaro-Nova rear \$487.00
- AS-1016CF** 1937-39 for Ford and others \$487.00
- AU-2229A** Spring Pads added to above kits add \$16.00
- Add gas shocks to all kits add \$20.00



BASIC REAR END MOUNTING KIT

Bolt-on kit includes right and left front and rear spring mounts, hardware, and instructions. Kits use Dodge springs or Chassis Engineering slider springs. Note: 1941-48 require a wider rear end. Use a rear that measures at 60 inches wheel flange to wheel flange. 1968-1975 Nova is ideal.

- AS-1018** 1937-39 \$109.50

BRAKE PEDAL & MASTER CYLINDER MOUNTING KIT

Bolt-in mounts adapt Ford Mustang (non-power) master cylinders to '37-'48 Chevy cars. '41-'48 mount uses original pedal arm. '37-'39 is a complete assembly with swing arm and mount. Both units are bolt in.

- AS-1026** 1937-'39 \$160.50
- AS-1041** 1941-'48 \$84.50



1940-48 Chevy Hot Rod Suspension Parts

1940-1948 Chevy Suspension



CP-1107

CP-1107G

ENGINE MOUNTING KIT - SMALL BLOCK CHEVY V-8

Chassis Engineering Engine mounts and crossmembers are especially engineered to work with Chevy's unusual "Top Hat" frame design. Kits Includes bolt on frame adapters (can be welded on) Chassis Engineering engine side mounts, thru bolt cushion set, bolts and instructions. Easy to install. For 1958 and up engines.

- CP-1106** 1940 Solid Axle \$102.90
- CP-1106A** 1940 Original Chevy IFS \$102.90
- CP-1106GB** 1940 Use with Competition Engineering or other bolt-in Mustang II IFS kits \$102.90
- CP-1107** 1941-48 Original Chevy IFS \$102.90
- CP-1107G** 1941-48 Use with Competition Engineering or other bolt-in Mustang II IFS kits \$102.90

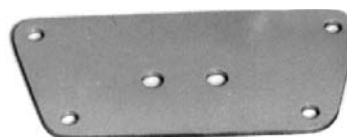

TRANSMISSION MOUNTING PLATE

For use with only V-8 engines. Bolt-on plate fits original crossmember. with minor modifications. Bolts and instructions included. For 350 Turbo, most powerglide and standard transmissions.

- ES-1170** 1940-48 \$21.00

GENERAL SWAP INFORMATION

Chassis Engineering engine mount kits are bolt-in, easy to use and solve two major problems associated with this swap: the transmission crossmember is not cut and there is clearance around the steering box to use a stock exhaust manifold. NOTE: the 1940 frame is different. Most parts will interchange, but not all.



RADIATOR SUPPORT

For use with Mustang II crossmember or for anyone who needs a replacement.

- AU-2255** 1940-48 \$57.35

1940-1948 Chevy Suspension



**BOLT-ON PINTO/MUSTANG II I.F.S.
WITH ADJUSTABLE RIDE HEIGHT**

Fully bolt-on crossmember uses Pinto/Mustang II suspension components. Stock Pinto-Mustang geometry is built in so there is no bump steer or other unpleasant surprises. Upper coil spring pads are adjustable, giving a 2 1/2" ride height adjustment at the wheels, an excellent method of fine tuning final ride height. Includes strut rod frame brackets with reinforcing rods built in for extra strength. Upper spring pads interlock with crossmember for rigidity. An easy way to get late model suspension, steering and brakes on a classic Chevy

- IF-4040CP** 1940 Chevy **\$625.00**
- IF-4148CP** 1941-48 Chevy **\$625.00**
- AU-2255** 1940-48 Radiator Support **\$52.00**



MUSTANG II FRONT CROSSMEMBER KIT

This kit includes lower crossmember, upper spring mounts, boxing plates, rear strut mounts, gussets and instructions to mount '74-'78 Mustang II or '74-'80 Pinto/Bobcat front suspension to your '40 to '48 Chevy. Gives a low stance and nice ride. Note: requires extensive welding. Economy kit does not have dressed welds

- CX-103** 1940-48 Heidt's Weld-in crossmember . **\$399.00**
- 1940-48 sway bar kit **\$134.50**

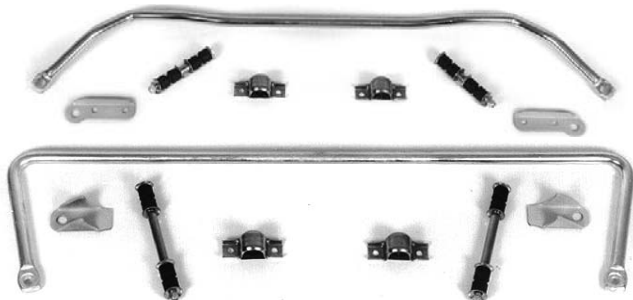

FRONT & REAR SWAY BAR

An ideal combination with our dual leaf rear end kit. Eliminates road sway and makes the top heavy Chevys into an excellent cornering and handling car. For best results use front and rear sway bars together. All linkage and mounting hardware furnished. State rear housing size. Rear must be used with CE rear shock kit.

- SB-1041PM** 1940-48 Front - Pinto/Mustang II IFS . . **\$129.50**
- SB-1041R** 1940-48 Rear - use with C.E. kit **\$134.50**

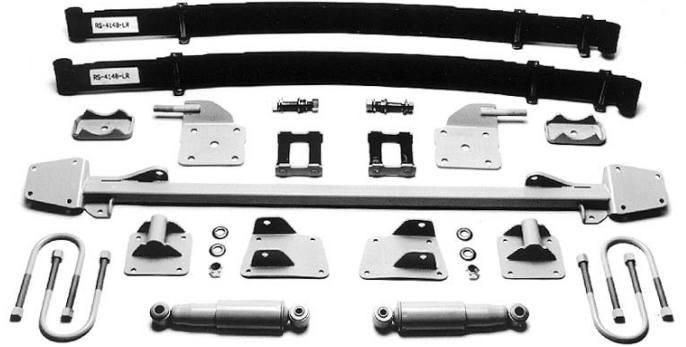

REAR END MOUNTING KIT

Bolt-on kit with no modifications of any kind to rear end. Easy installation, just remove old mounts and bolt these in their place. Kits include right and left front and rear spring mounts, 4 U-bolts and nuts, rear shock kit with spring retainers, shocks, shackles, slider springs, bolts, and instructions. Kits use 1968-1976 Nova multi-leaf rear ends or 1967-1969 Camaro or Firebird. Best choice is the Ford Granada and Monarch rear ends (8 inch). To use other rears, spring pads must be welded on rear end. Note: 1941-48 require a wider rear end. Use a rear that measures at 60 inches wheel flange to wheel flange. 1968-1975 Nova is ideal.

- AS-1020CC** 1940 only for Camaro-Nova rear **\$484.00**
- AS-1016CF** 1940 only for Ford and others **\$484.00**
- AU-2229A** Spring Pads added to above kits **add \$16.00**
- AS-1019C** 1941 includes weld on spring pads **\$504.50**
- Add gas shocks to all kits **add \$20.00**



BASIC REAR END MOUNTING KIT

Bolt-on kit includes right and left front and rear spring mounts, hardware, and instructions. Kits use Dodge springs or Chassis Engineering slider springs. Use a rear that measures at 60 inches wheel flange to wheel flange. 1968-1975 Nova is ideal.

- AS-1019** 1941-48 Basic bracket kit **\$105.00**



MASTER CYLINDER MOUNTING KIT

Bolt-in mounts adapt Ford Mustang (non-power) master cylinders to '41-'48 cars. Mount uses original pedal arm.

- AS-1026** 1941-48 Bolt-in master cylinder mount . **\$77.50**